

## Mediating Role of Organizational Commitment: Hrm Factors Affecting the Employee Performance

Sadaf Ambreen \*

Tasawar Javed †

Nausheen Syed ‡

**Abstract** *This review expects to analyze the effect of human assets, the executives' arrangements on hierarchical responsibility, and the exhibition of the representatives. The review encased the strategies factor as an autonomous variable and the representative's exhibition as a reliant factor. This concentrate additionally plans to explore the job of association, the job of "hierarchical responsibility," as a middle person variable between the arrangements if (HRM) and the exhibition of the worker and to accomplish these points. The specialist has utilized the expressive scientific strategy, which addressed utilizing to check the construction reality of the review factors coming to utilize. The review has closed many outcomes, and quite possibly, the main result is that there is a positive association between human resources, the leaders, and the worker's presentation. The concentrate likewise tracked down an aberrant constructive outcome to the executives' human asset through the association responsibility with the rate higher than the immediate effect; the exploration progressed that all police creators of HRM and result in growing the representative's presentation.*

- DOI: 10.31703/gssr.2021(VI-I).48
- Vol. VI, No. I (Winter 2021)
- Pages: 477 – 486
- p- ISSN: 2520-0348
- e-ISSN: 2616-793X
- ISSN-L: 2520-0348

**Key Words:** Organizational Performance, Employee Performance, Human Resource Management

### Introduction

The vital component to the continuation of the given organization is the accessibility of the ideal individual at the ideal spot and the ideal opportunity. As demonstrate by many firms, people address a wellspring of an aggressive benefit unrefined of whether those individuals are visionary supervisors, circumspect the client assistance master, or even mechanical specialists. When innovative advancement is unequal, just the human asset can assume a significant part in the achievement or disappointment of the relative multitude of firms, explicitly pioneering firms. There might be a consciousness of the fast and muddled changes in the market climate with the association and chiefs. Individuals in the association, as seen by top administration, are viewed as the most significant key assets.

Those associations which have long-haul destinations normally make endeavors to

reevaluate how to deal with HR. This is known as a human resource the leaders, which is a term showing how such affiliations give a lot of significant jobs in dealing with their human asset. Inside the rise of HRM, as of late, analysts have given a lot of consideration to this, explicitly the impact of human asset rehearses on the presentation of associations and representatives' perspectives as a fascinating exploration region, particularly with regards to extended nations. However, little is thought about the effect of HRM regarding non-industrial nations (Sarbariy, 2011). This proposes the requirement for additional examination on HRM in non-industrial nations like Asia or Africa. It is also expected that examining this exploration region will work as a vehicle for moving toward contemplates. Past examinations researching the impact of HRM on hierarchical execution have zeroed various ventures (Davision et al., 1996; Wyatt's, 2002). In

\* Lecturer, Department of Management Sciences, Government College Women University, Faisalabad, Punjab, Pakistan.

† Assistant Professor, Institute of Business Management and Administrative Science, The Islamia University of Bahawalpur, Punjab, Pakistan.

‡ Assistant Professor, Department of Management Sciences, Government College Women University, Faisalabad, Punjab, Pakistan. Email: [nausheen.dr@gmail.com](mailto:nausheen.dr@gmail.com)

any case, experts (Inchniowski et al., 1995) bring up that HRM may give benefits when it centres on this in the industry sector. Likewise recommended that evaluation of HRM in the industry brought about the real estimation of authoritative execution, HRM practices, and control factors.

### Issues

Along, Although HRM accepts a huge part in preferring the show of delegates and affiliations, various relationship in non-modern countries, for instance, the United don't give a great deal of thought to HRM to give such effective execution of their laborers. There are, honestly, several connected assessments on HRM in Africa by and large and united, particularly see worldwide. Additionally, these a few investigations in the united setting focused on their assessment of HRM and laborers' show while ignoring the meaning of legitimate liability. Consequently, the current review means to inspect the impact of HRM on representatives' presentation through authoritative responsibility as an arbiter variable to overcome any barrier referenced above in past research.

### Objectives

The review's fundamental goal is to look through the effect of HRM rehearses on representative execution and hierarchical responsibility in United Bank Ltd. as the review setting. To accomplish this level headed, the accompanying explicit goals are expressed:

1. To investigate the relationship between HRM and employees' performance.
2. To investigate the relationship between HRM and employees' performance through the mediator variables of organizational commitments.

### The rationale of the study

The case finished in the current audit is checked to impact laborers' show clearly and by suggestion through various leveled liability as an arbiter variable.

### Literature Review

#### Human Resource Management

In its underlying turn of events, the US board idea of HRM shows the consideration and significance given to individual specialists or representatives

and the requirement for considering them as resources instead of cost ([Wilkinson, 1990](#)). Albeit the idea got wide acknowledgement as new administration rehearses, it has stayed vague due to its various applications. There are three significant ways to deal with HRM. In the first place, HRM is considered as another title for specific administration, showing that associations ought to rename their elective office without rolling out any improvements to their practices. Plus, HRM is seen as the understanding and affirmation of select positions and portrayals created by the work power office. Thirdly, HRM is seen as a new way to deal with unmistakably overseeing starts and coordinating HR into vital administration. Consequently, this third way to deal with HRM keeps up with the significance of completely and decidedly using full and HR. In a word, HRM alludes to arrangements created to boost authoritative blend, workers' responsibility, adaptability, and quality ([Li et al., 2020](#)).

#### Employee Performance

towards the positions has been a huge concern for the two affiliations and scholars. For a significant long time, affiliations and researchers have been glancing through indisputable means to redesign or additionally foster specialist execution. Thusly, work execution is the delegate's practices or exercises identified with the focuses or goals of the affiliation being alluded to."

[Christen et al. \(2006\)](#), [Rayton \(2006\)](#), and [Zhang \(1999\)](#) argue that work fulfilment as an attitudinal variable affects or impacts their work execution which is a conduct variable. In light of the aftereffects of their exact review, Lawler and [Porter \(1968\)](#) expressed the workers' fulfilment with higher-request firmly connected with their work execution. In past examinations researching the impact of workers' fulfilment to work execution, settled still is the easygoing course towards work fulfilment and occupation execution ([Ashraf, Li, Butt, Naz, & Zafar, 2019](#)).

[Porter \(1990\)](#) sees or characterizes authoritative responsibility as the steady inclination of workers to connect with or participate in explicit exercises identified with their association. It results from representatives' interest in this association and their apprehensions about losing their positions in case they are not dedicated to their work.

Hierarchical responsibility is viewed as an implies that doesn't just interface workers to the points or objectives of their association yet, in addition, makes among them a feeling of qualities and acknowledgement of these recognized objectives and puts forth their willingness to place into many attempts for the benefit of the association to endure and proceed with its participation (Rebecca, 2013).

Qaisar et al. (2012) similarly portrayed legitimate liability as per a psychological perspective. It is portrayed as a psychological strategy for partner individuals to their affiliation,

rousing them to work all the more eagerly and pushing them to take on the affiliation's characteristics, in this way unequivocally affecting the productivity and reasonability of their affiliation. Some past researchers uncovered outcomes certifying that various levelled liability has basic responsibilities to achieving affiliations' destinations and accomplishing the work within a short period, least effort and cost. This is because it convinces delegates to work all the more excitedly or associate significantly in their work (Ashraf, Li, & Mehmood, 2017).

## Conceptual Framework

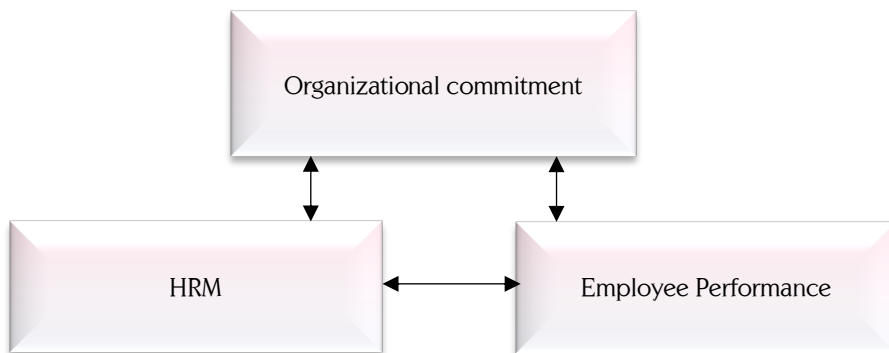

Figure 1

## Hypothesis

- H1:-** There is a significant positive correlation between human resource management and employee performance.
- H2:-** There is a significant positive correlation between human resource management and organizational commitment.
- H3:-** There is a significant positive correlation between organizational commitment and employee performance.
- H4:-** There is a significant positive correlation between human resource management and employee performance through organizational commitment.

## Research Methodology

### Data Collection

For this review, information was gathered from essential and optional sources. The essential source is addressed by reviews, while the auxiliary source incorporates a broad work area

through the library, distributed materials, and websites. A poll was created to quantify human assets the board rehearses, representative execution, and the association's commitment. Overviews are viewed as a more straightforward way to deal with information assortment (Yu and Agri, 2005). Concerning the human asset the executives rehearse in the survey, the examination components incorporate five measurements: enrollment and determination strategy, investment strategy, execution evaluation strategy, award and prize arrangement, and preparing and improvement strategy. All components of this human asset the executives rehearses come from an audit of past human asset writing, which was expressly embraced by past analysts (Pfeffer, 2005; Rubino, Demo & Traldi, 2011). Employee performance is evaluated through four dimensions: productivity, innovation and effort, work planning, creativity; the elements of these constructive variables are taken from Nasazi

(2012). The mediating variable organizational participation comprises three dimensions: emotional participation, sustainable participation and normative participation.

This questionnaire consists of three sections (20) items or questions that the respondents have to answer using a five-point Likert scale: 1 = totally disagree, 5 = agree. Accordingly, the questionnaire was translated into Arabic for the participants before conducting the questionnaire, as the researcher didn't use English. The indication of the researcher's intention to collect data was included. The researcher then distributed 155 questionnaires to the respondents, while the response questionnaires (107) had a rate of around 84%. In addition, a few of the questionnaires were missing information and were removed. A questionnaire of 107 questionnaires was found useful and included in the statistical analysis. Questionnaires were distributed, collected and collected between December 1st and 31st (2020).

### Sampling

In this study, the employees of the UBL FSD represent the target group. However, 155 employees were randomly selected to participate in this study. Random sampling was used for this purpose.

### The Proposed Hypotheses are

**H1:** There is a positive and significant relationship between employee performance and Human Resources Management

The research hypothesis affirmed the positive and direct impact of staff strategy on employee performance. Figure 6, Table 6 presents the yield from Amos. This exploration theory was measurably huge because (CR) (5618) was greater than (1.964), and the significance level value (0.05) was less than (0.05). In addition, the path coefficient was (0.35), a determining trend that confirms that the personnel management policy leads to an increased performance development of the employees.

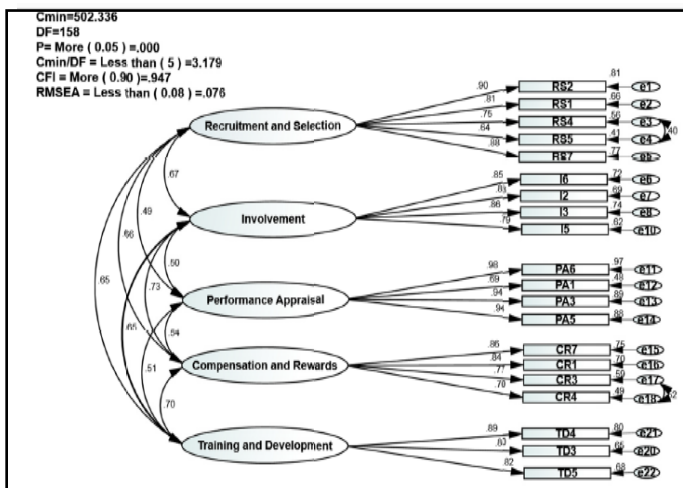

Figure 2: Human Resources Management Model after Amendment

Table 1. Covariance and the contrast between the extracted five-Factor Matrix (HRMPPS) Model

S. No	Factor	Recruitment	Involvement	Performance	Compensation	Training
1	Recruitment	0.64	-	-	-	-
2	Involvement	0.45	0.54	-	-	-
3	Performance	0.24	0.25	0.81	-	-
4	Compensation	0.44	0.53	0.29	0.63	-
5	Training	0.42	0.42	0.26	0.49	0.71

**(H2):** A positive and significant relationship between organizational commitment and human resources management

The second research hypothesis also emphasized the critical and direct impact of HRM on the participation of organizations. As shown in Figure (6) and Table (6) shows that effect was significant with the values of CR, which was higher than (1.964) and significant.

The value (.000) was below (0.05). In addition, the path coefficient was (0.75), suggesting that this effect points in a critical direction and confirms that increased interest in human resource management leads to greater commitment to the organization. Accordingly (57%), the organization's participation is attributed or explained by the HR department, which is significant to the variables.

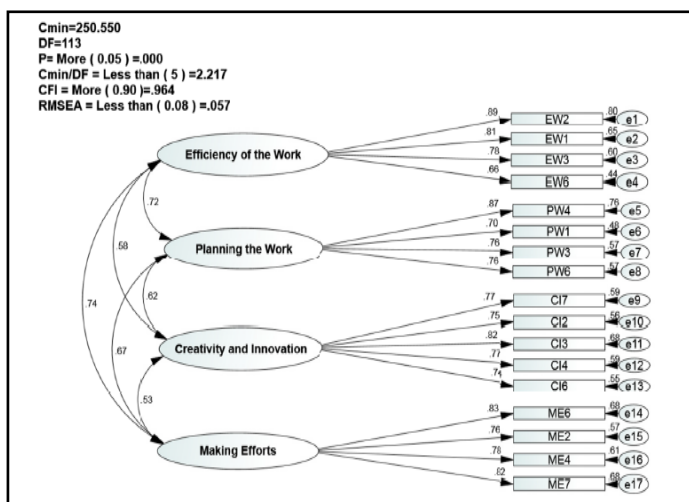

Figure. 3: Employee Performance Model after Amendment

Table 2. Covariance and the Contrast between the Extracted Four-Factor Matrix Employee Performance Model

S. No	factor	Efficiency	Planning	creativity	Making Efforts
1	Efficiency	0.62			
2	Planning	0.52	0.60		
3	creativity	0.34	0.38	0.59	
4	Making Efforts	0.55	0.45	0.28	0.64

**(H3):** A Significant and Positive Relation between Employee Performance and Organizational Commitment

H3 showed a direct and decisive effect of organizational participation on employee performance and is shown in Figure (6) and Table (6). The effect mentioned in the research that hypothesis was significant with values of CR

(9.794) is higher than (1.964), and the significance level (0.000) is less than (0.05). In addition, the path coefficient reached (0.67), which indicates a positive trend and shows an increased interest in the organization's participation in the advancement of representative execution. The outcomes additionally show the general effect on employee performance.

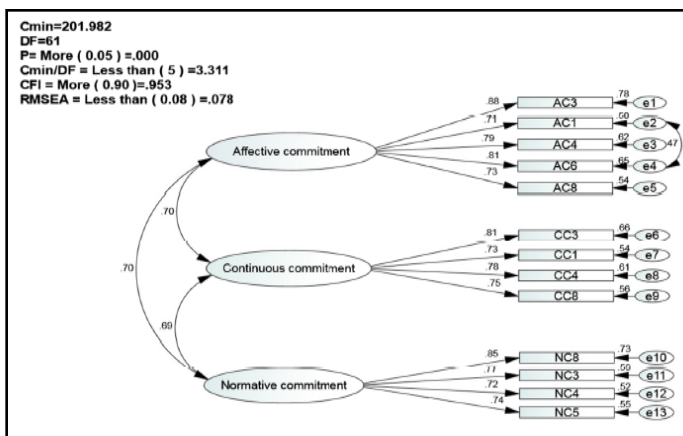

Figure 4: Organizational Commitment Model after Amendment

Table 3. Covariance and the Contrast between the Extracted Three-Dimensional Matrix Organizational Commitment Scale

S. No	Latent Variables	Affective Commitment	Continuous Commitment	Normative Commitment
1	Affective Commitment	0.62	-	-
2	Continuous Commitment	0.49	0.59	-
3	Normative commitment	0.49	0.47	0.60

(H4): A positive and significant correlation between employees and Human Resources Management

The study hypothesis confirmed the positive and indirect effects of human resource management on employee performance—the influence of HRM on employee performance through the

intermediary factor, the performance of the organization. Table 7 shows the value of this indirect effect (0.50) is the amount obtained by multiplying the relationship path between human resource management and organizational engagement (0.75) and the path factor employee performance and organizational participation are (0.67).

Table 4. Values of the Fit Indices of the Model

Indicators Consistency	Measurement Model Figure 5	Structural Model Figure 6	Function value on the quality of conformity
	index value	index value	
Cinin	78.894	78.894	...
df	51	51	...
P	.0070	.0070	None
CininDf	1.547	1,547	Less than (5)
CFI	.9900	,9900	More (.90)
RMSEA	.0380	.0380	Less than (.08)

Conclusion and Results

The fundamental motivation behind this review was to inspect the effect of human asset

rehearses on representative execution and corporate strategy consistency in the US banking industry. The examination finished with many



outcomes. Quite possibly, the main result is the positive connection between individuals on the board and worker execution. The worth of the pattern got is 0.35, with a positive trend.

**Table 5.** Parameter and Non-Parameter Estimates of Tlie Theoretical Measurement Model

Latent variables	Observed variables	estimate	SE.	C. R.	P	Loading	SMC
Human Resources	Recruitment and Selection	1.000	-	-	-	0.79	0.62
	Involvement	0.815	0.050	16.372	\$\$\$	0.79	0.62
	Performance Appraisal	0.734	0.054	13.686	\$\$\$	0.68	0.46
Management	Compensation and Rewards	0.875	0.051	17.091	\$\$£	0.82	0.67
	Training and development	0.605	0.039	15.553	\$\$\$	0.76	0.57
Organizational commitment	Affective Commitment	1.000	.	.	.	0.82	0.68
	Continuous Commitment	0.807	0.049	16.576	***	0.77	0.60
	Nonnative Commitment	0.831	0.049	17.090		0.79	0.63
Performance of employees	Efficiency of the work	1.000	-	-	-	0.82	0.66
	Planning the Work	0.964	0.055	17.643	* * *	0.80	0.64
	Creativity and innovation	0.986	0.070	14.135	***	0.67	0.46

S.E Standard Error, CR: Critical Ratio. P: Probability. SMC: Squared Multiple Correlations.

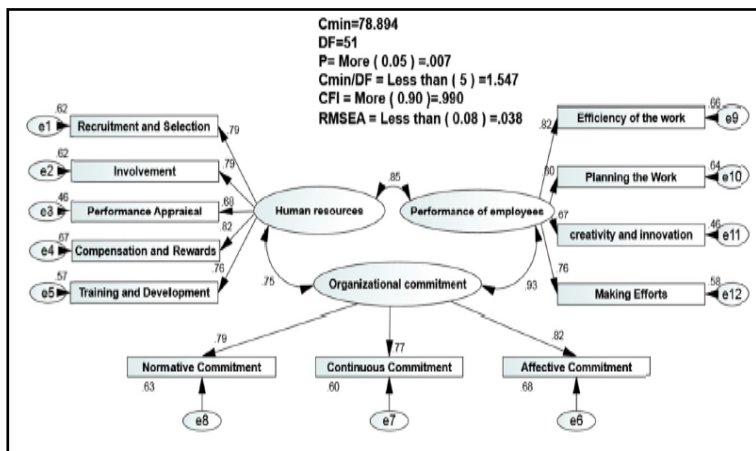

**Figure 5:** Modified Measurement Model

This high percentage of employee performance is achieved thanks to the political factor. These results agree with (Demo, Neiva, Nunes, Rosette (2012), Guest and Conway (2011) and Beauvallet

and Houy (2010). The value of the trend between policy factor and compliance is 0.75, which indicates a positive trend. In addition, the direct effect between them is 0.57. In addition, the

trend value between the organizational engagement factor and employee performance is 0.67 in the positive direction of these results are consistent with several types of research.

**Table 6.** Results of the Levels of Correlations between the factors of Mo

Latent Variable	S. R. W	Latent Variable	E	S. E	C. R	P-value	S. R. W
Human Management Resources		employee performance	0.277	0.049	5.618	0.000	0.35
Human Management Resources	→	organizational commitment	0.70S	0.055	12.784	0.000	0.75
organizational commitment	→	employee performance	0.572	0.05S	9.794	0.000	0.67

*RSW: Standardized Regression Weights. CR: Critical Ratio. SE: Standard Error, E: Estimate,*

**Table 7.** Results of the Levels of Effect between the Factors of the Model

Independent	Mediation	Dependent	Indirect effect	Total Effect	Indirect Effect Test Result Sobel Test		
					S.T.S	O.T. P	T.T. P
HRM	Organizational commitment	Employee Performance	0.50	0.85	8.814	.000	.000

This study also found an indirect positive impact on human resource management policy by engaging the organization faster than the direct impact. In contrast, the indirect effect value is 0.50. This finding was confirmed by [Yazam and Ahmad \(2012\)](#). Finally, the researcher recommends that all human resource management policymakers be mindful of employee policies and practices to develop employee performance. Strategy in the bank ought to likewise zero in on the enthusiastic parts of workers, which has a more constructive outcome on their exhibition than on their immediate effect.

### Limitations and Future Studies

While this review has numerous hypothetical and down-to-earth suggestions, various constraints offer amazing freedoms for future investment in this significant examination region. To begin with, speculation of the outcomes to different nations is restricted as the review zeroed in on the financial area in the United States. Future examinations could test the connection between HR and representative execution in one more country in a similar district. Second, the plan of the cross-sectional hunt can be another limit. Extra examination utilizing longitudinal strategies looks at the connection between human asset the board and worker execution through another transitional variable.



## References

- ALDamoe, F. M. A., Yazam, M., & Ahmid, K. B. (2012). The mediating effect of HRM outcomes (employee retention) on the relationship between HRM practices and organizational performance. *International Journal of Human Resource Studies*, 2(1), 75-88.  
<http://dx.doi.org/10.5296/ijhrs.v2i1.1252>
- Armstrong, M. (2009). *Armstrong's handbook of human resource management practice* (11th ed.). London.
- Barney, J. (1991). Firm resources and sustained competitive advantage. *Journal of Management*, 17(1), 99-120.  
<http://dx.doi.org/10.1177/014920639101700108>
- Beauvallet, G., & Houy, T. (2010). Research on HRM and lean management: a literature survey. *International Journal of Human Resources Development and Management*, 10(1), 14-33.  
<http://dx.doi.org/10.1504/IJHRDM.2010.029444>
- Beck, K., & Wilson, C. (2001). *Have we studied, should we study, and can we study the development of the development of commitment? Methodological issues and the developmental study of work-related commitment.*
- Bohlander, G. W., & Snell, S. (2009). *Administração de recursos humanos* (14th ed.). São Paulo: Cengage.
- Boselie, P., Dietz, G., & Boon, C. (2005). *Comunalities and contradictions in HRM and performance research.*
- Boxall, P., & Purcell, J. (2000). Strategic human resource management: where have we come from e where should we be going? *International Journal of Management Reviews*, 2(2), 183-203.  
<http://dx.doi.org/10.1111/1468-2370.00037>
- Browne, M. W., & Cudeck, R. (1993). *Alternative ways of assessing model fit.* Sage. Focus Editions, 154, 136.
- Chênevert, D., & Tremblay, M. (2009). Fits in strategic human resource management and methodological challenge: Empirical evidence of influence of empowerment and compensation practices on human resource performance in Canadian firms. *The International Journal of Human Resource Management*, 20(4), 738-770.  
<http://dx.doi.org/10.1080/09585190902770547>
- Christen, M., Iyer, G., & Soberman, D. (2006). Job satisfaction, job performance, and effort: A reexamination using agency theory. *Journal of Marketing*, 70(1), 137-150.
- Hair, J., Black, B., Babin, B., Anderson, R., & Tatham, R. (2006). *Multivariate Data Analysis* (6th ed.). UpperSaddle River, NJ: Prentice-Hall.
- Oladipo, J. A., & Abdalkader, D. S. (2011). Strategic Human Resource Management and Organizational organizational commitment. *Human Relations*, 40(7), 445-70.
- Pfeffer, J. (2005). Producing sustainable competitive advantage through effective management of people. *Academy of Management Executive*, 19(4), 95-108.
- Porter, L. W., & Lawler, E. E. (1968). *Managerial attitudes and performance.* Homewood, Ill.: R.D. Irwin.
- Porter, M. (1990). *The Competitive Advantage of Nations.* The Free Press, A Division of McMillan, Inc., New York.
- Qaisar, M., Safdar, R., & Sufyan, M. (2012). Exploring Effect of Organizational Commitment on Employees' Performance. *Interdisciplinary Journal of Contemporary research in Business*, 3(11), 248-255.
- Rayton, B. A. (2006). Examining the interconnection of job satisfaction and organizational commitment: An application of the bivariate probit model. *The International Journal of Human Resource Management*, 17(1), 139-154.
- Rebecca, A., Stephen, G., Mahima, S., Howard, M., & Shelley, M. (2013). The Influence of Organizational Commitment and Individual Competence on Performance: In the Learning Organization Perspective. *International Journal of Business and Behavioral Sciences*, 3(8), 20-36.
- Rubino, T., Demo, G., & Traldi, M. T. F. (2011, April). *As políticas de gestão de pessoas influenciam o bem-estar no trabalho? Proceedings of the Congresso Iberoamericano de Psicologia das Organizações edo Trabalho, Florianópolis, SC, Brazil*, 2.

- Sarbariya, R., & Khita, A. R. (2011). *Human Resource Practices and Its Effect on Employee Job Satisfaction: A study on selected small and medium sized iron & steel firm in India public policy and administration research.*
- Scarpello, V., Ledvinka, J., & Bergmann, T. (1995). *Human resource management: Environments and functions (2nd ed.)*. Cincinnati, OH: Southwestern College Publishing.
- Tanveer, Y., & Zeeshan, M. (2011). The way Human Resource Management (HRM) Practices Effect Employees Performance: A Case of Textile Sector. *International Journal of Economics and Management Sciences, 1*(4), 112-117.
- Ulrich, D., Halbrook, R., Meder, D., Stuchlik, M., & Thorpe, S. (1991). Employee and customer attachment: synergies for competitive. *Human Resource Planning, 14*(2), 89-102.
- Uysal, G. (2012). For the development of effective HRM systems: inter-relationships between HRM practices using correlation analysis. *World Review of Entrepreneurship, Management and Sustainable Development, 8*(1), 1-12. <http://dx.doi.org/10.1504/WREMSD.2012.044483>
- Vakola, M., Soderquist, K. E., & Pratascos, G. P. (2007). Competence management in support of organizational change. *International Journal of Manpower, 28*(3/4), 260-275. <http://dx.doi.org/10.1108/01437720710755245>
- Wilkinson, A. (1990). *Business Strategy and the management of Labour (University of Durham PhD. working paper 5333)*. Columbia University.
- Yu, B. B., & Egric, C. P. (2005). *Human resource Management Practices and affective organizational commitment: A comparison of Chinese employees in a state-owned enterprise and a joint venture.*
- Zhang, Z. (1999). *Developing an instrument for measuring TQM implementation in a Chinese context. SOM Research Report, 99A48*, University of Groningen, Groningen.
- Ashraf, S. F., Li, C., Butt, R., Naz, S., & Zafar, Z. (2019). *Education as Moderator: Integrative Effect towards Succession Planning Process of Small Family Businesses*. *Pac. Bus. Rev. Int, 11*, 107-123.
- Ashraf, S. F., Li, C., & Mehmood, B. (2017). A Study of Premium Price Brands with Special Reference to Willingness of Customer to Pay. *International Journal of Academic Research in Business and Social Sciences, 7*(7), 619-639.
- Li, C., Ashraf, S. F., Shahzad, F., Bashir, I., Murad, M., Syed, N., & Riaz, M. (2020). *Influence of Knowledge Management Practices on Entrepreneurial and Organizational Performance: A Mediated-Moderation Model*. *Frontiers in Psychology, 11*, 2862.